



MARCEL MINARIČ – OBCHODNÝ MANAŽÉR I DEALER WEST

SCANIA PLYNOVÉ VOZIDLÁ

SCANIA



SCANIA a ekológia





SCANIA a ekológia

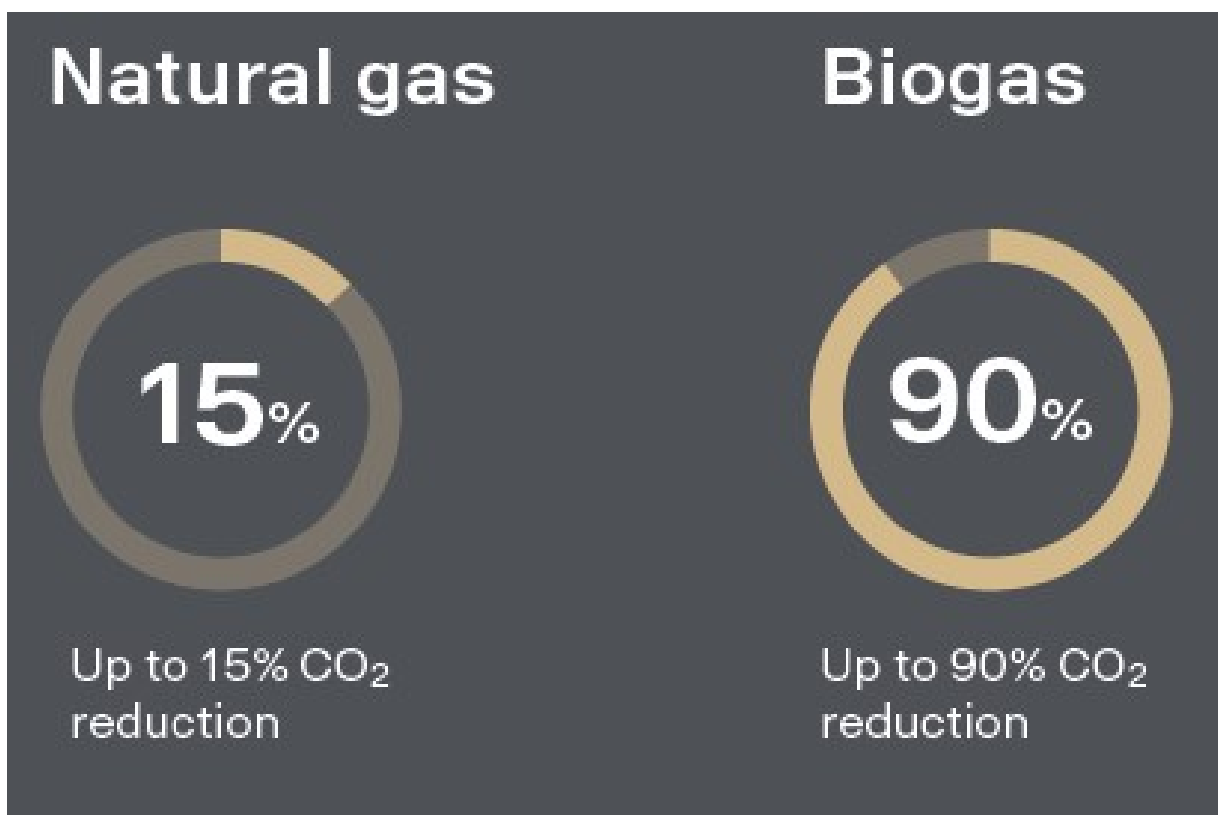



Rozsah špecifikácií

Plynové motory

280 k 1350 Nm

340 k 1600 Nm

410 k 2000 Nm

Konfigurácie náprav

4x2

6x2

Výška rámu

982 mm (+175 točnica)

978 mm (+175 točnica)



Motor

Ottov motor

Palivová zmes

Konštantný pomer

Zapaľovacia sviečka

Kompresný pomer

9:1

12,6 : 1

Tlak 80 – 140 bar

Výhody

Nižšia hlučnosť

Menej No_x

Bez Ad-Blue





Nádrže LNG

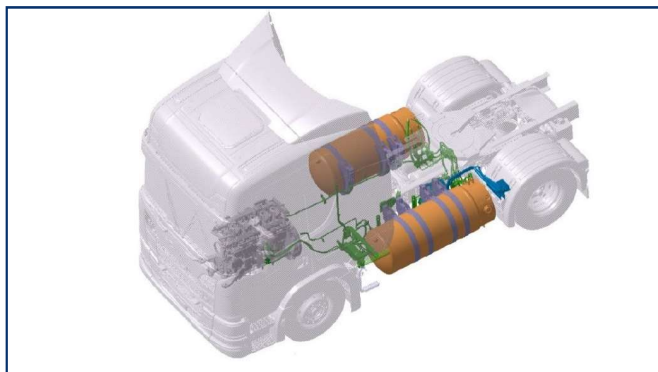

Ťahač

Vľavo 400 L

Vpravo 350 L

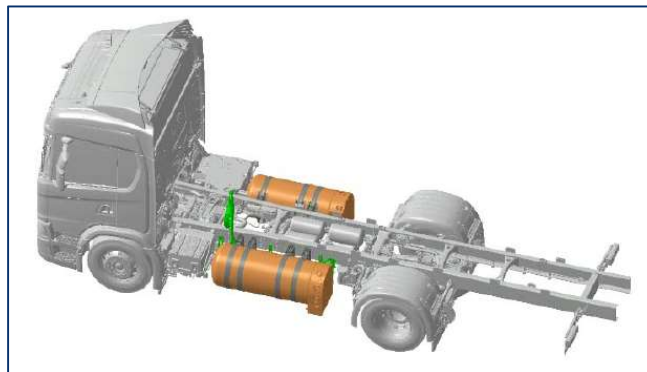

Podvozok

Vľavo 400 L

Vpravo 340 L

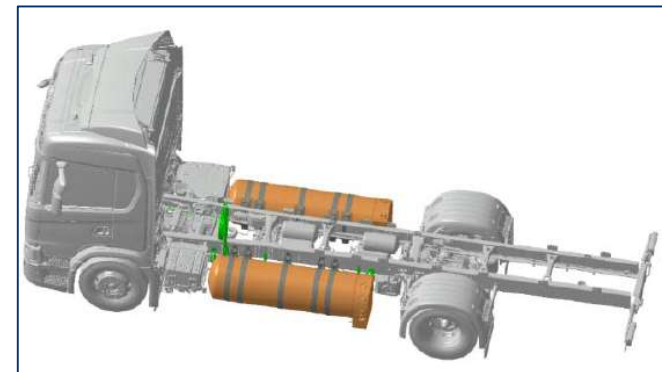

Podvozok

Vľavo 550 L

Vpravo 550 L



Nádrže CNG



Ťahač / podvozok
Vľavo 4 x 96 dm³
Vpravo 4 x 96 dm³

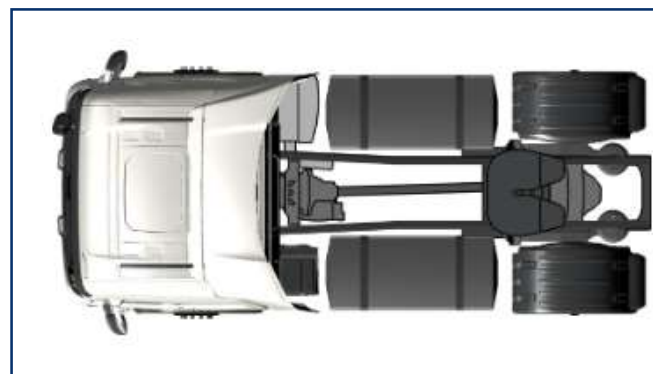

Ťahač / podvozok
Vľavo 4 x 118 dm³
Vpravo 4 x 118 dm³



Kabíny



Nízka „L“



Denná „G“



Spacia „R“



Aplikácie



Preprava odpadu



Mestská rozvážka



Regionálna
distribúcia



Diaľková doprava



Servis

Servisný interval 45 000 km

Výmena zapalovacích
sviečok

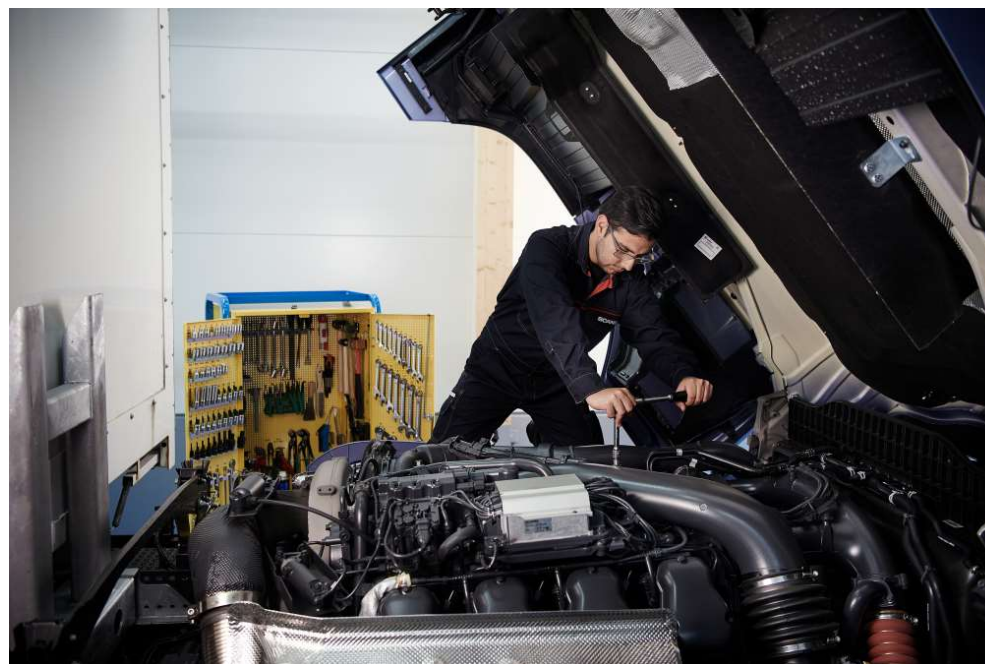



Testovanie Scania LNG v SR

19.11. – 30.11.

6 dopravcov
4895 km

Spotreba paliva / 100km

Priemer 23,5 kg

Najnižšia 19,8 kg

Najvyššia 28,4 kg

Celková hmotnosť súpravy

Priemer 26 t

Najmenšia 18 t

Najväčšia 34,5 t

Trasy

Regionálne cesty SR

Diaľnica

Horský prechod

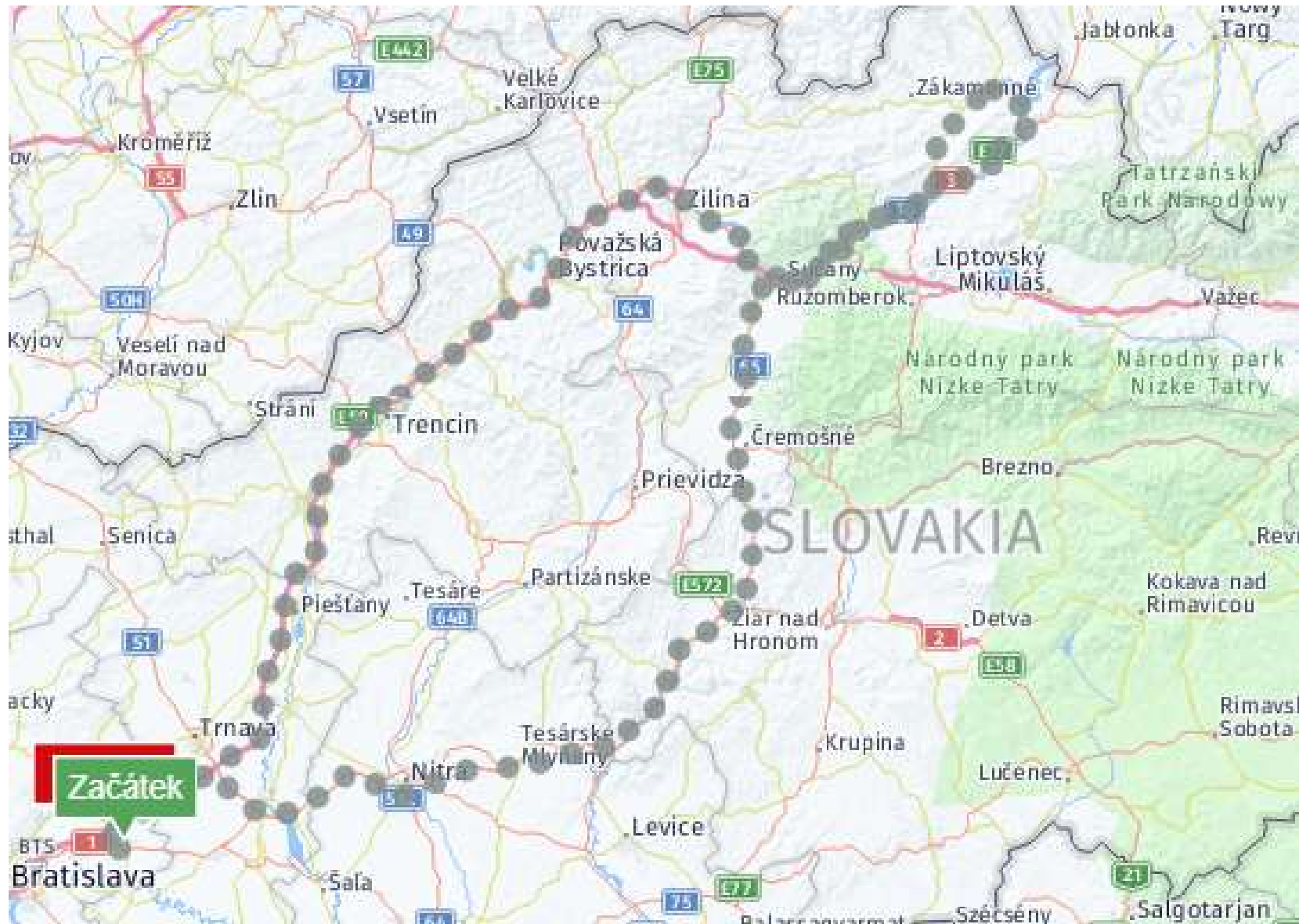



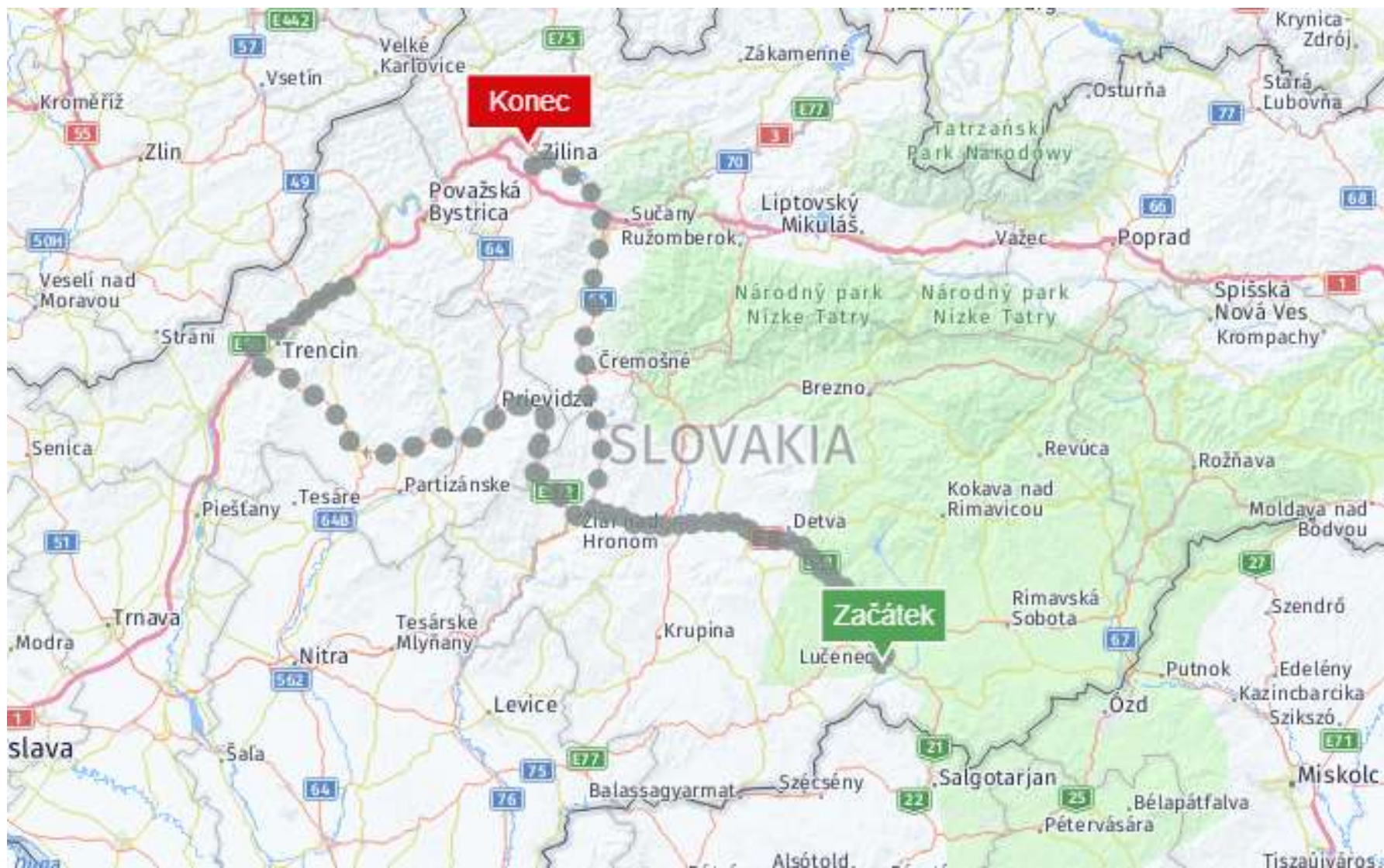



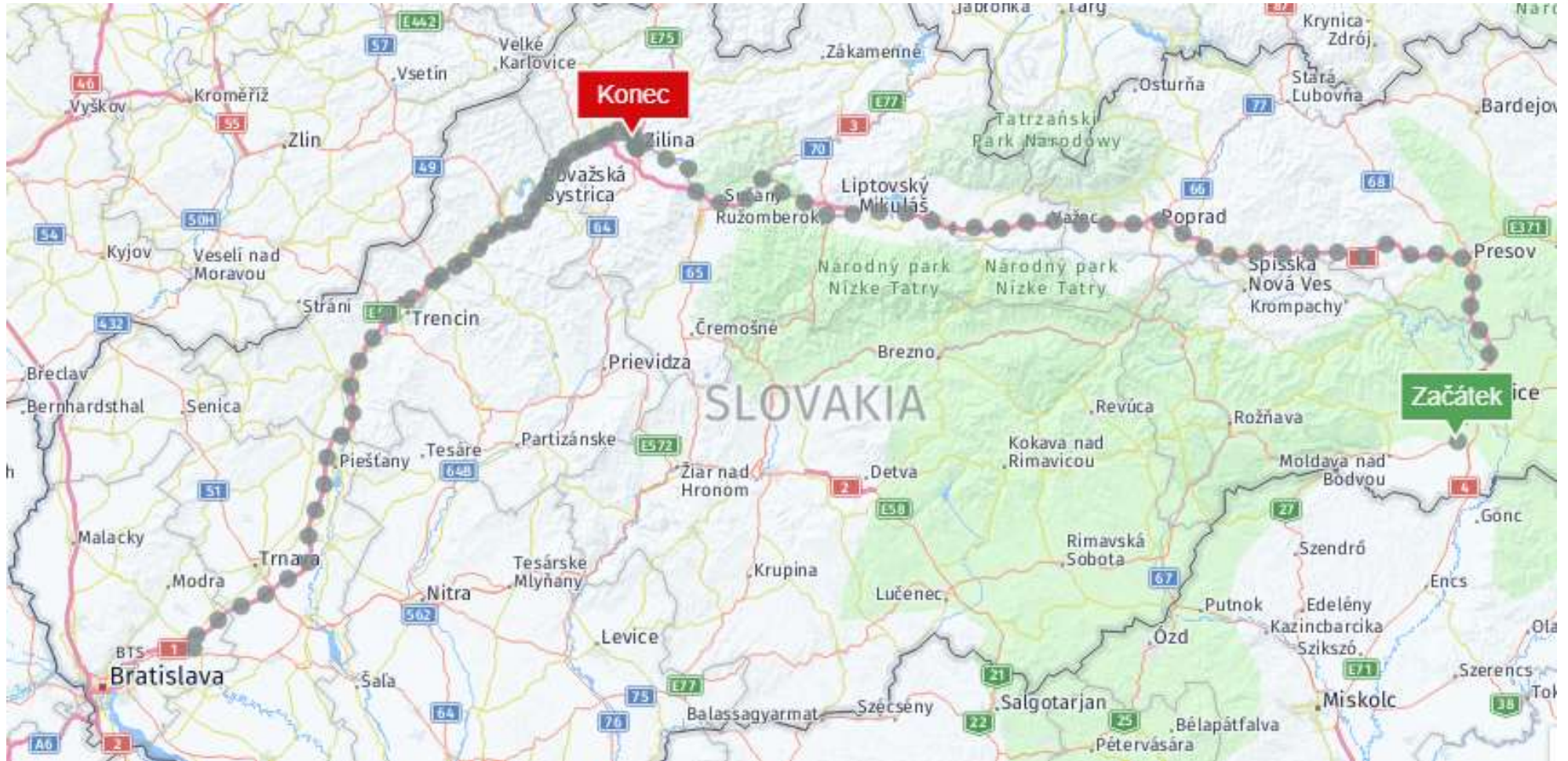









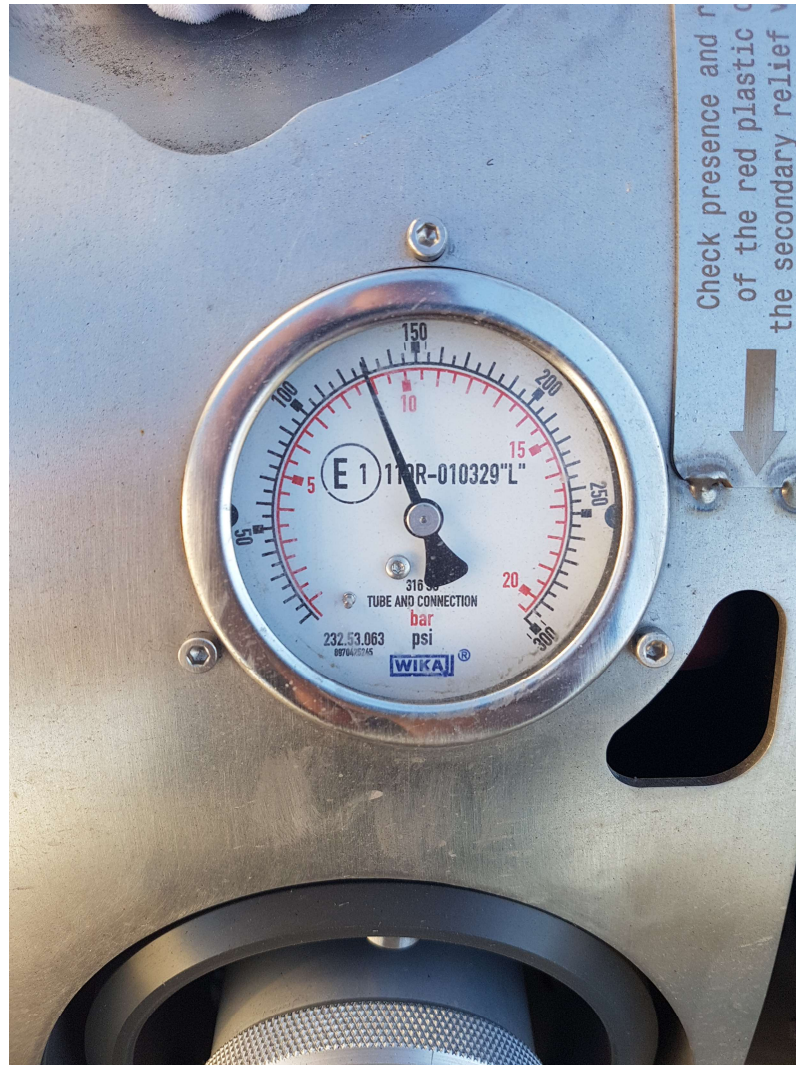



SCANIA

Marcel Minarič

Obchodný manažér – dealerská sieť | Dealer West | Scania Slovakia s.r.o.

marcel.minaric@scania.sk

+421 903 472 583